

Datasheet

version 1.0

FTC03DALI



Touch panel for DALI units control

Screen size 3.5"

1x serial port RS-232/RS-485

5 optional screens for scenes control

Adjustable screen for direct control of circuits

Adjustable screen for direct control of blinds

Mounting into panel, under the plaster or on the surface

Technical specification				
bus		DALI		
LCD display	technology		TFT LCD	
	screen		3.5"	
	resolution		320 x 240 (QVGA)	
	Number of colors		65536	
	Viewing angles (horiz/vertik)		120°/110°	
	brightness		450	cd/m ²
	contrast		300:1	
	backlight		LED	
	Lifetime of backlight		30000	hours
Power supply		18-32 (usually 24)	V ss	
Usual watage		8	W	
Maximal current		1	A	
touchscreen	technology		resistive	
	lifetime		1 million touches with silicon tip with diameter 8 mm	
conectors	Computer network		Ethernet 10/100Base-T	
	Serial port		COM1 (RS-232/RS-485)	
	USB port		USB2.0, 1x Host	
	Memory card slot		SDHC	
Connection of serial connector	RS-232	Pin connection	2-Rx, 3-Tx, 5-ground	
		DIP setting	1,2,6 - On, 3,4,5 - Off	
	RS-485	Pin connection	2-D+, 3-D-, 5-zem	
		DIP setting	3,4 - On, 1,2,5,6 - Off	
Ingress protection degree		IP65 front panel		
Ambient working temperature		0 ÷ 50	°C	
Storage temperature		-20 ÷ 60	°C	
weight		0.25	kg	
dimensions (width x height x depth)		120.79 x 85.5 x 26.5	mm	
Dimensions of cut		115 x 80	mm	

Functions

FTC03DALI is a touch panel for control of DALI units manufactured by Foxtron company. Connection to the DALI bus is done by DALI232 unit manufactured by Foxtron company.

Touch panel allows full user configuration. By DALI system units is possible to control switchable and dimmable circuits (mostly used for lighting control). Another possibility is to control blinds which are in special subgroup of switchable circuits.

Each circuits (dimmable, switchable and blinds) can be directly controlled in the screens for direct control of light and blind circuits. Those screens allows to show and diagnose malfunction of those circuits.

Each circuits can be furthermore controlled as a bulk by scenes. Scenes can be induced by button on any of the five screens, automatically on time, by dusk or dawn and by switching off another circuit. Scenes are possible to concatenate and cycle. Also their induction can be affected by state of some circuit.

Touch panels can be connected to the computer network and from one touch panel can be controlled scenes which belongs to the other touch panel connected to the network. Control program can be also installed separately on PC with Windows operational system which can be connected also in the network as one control unit.

Schematic connection of the FTC panels in the computer network and to the DALI bus is on following picture:

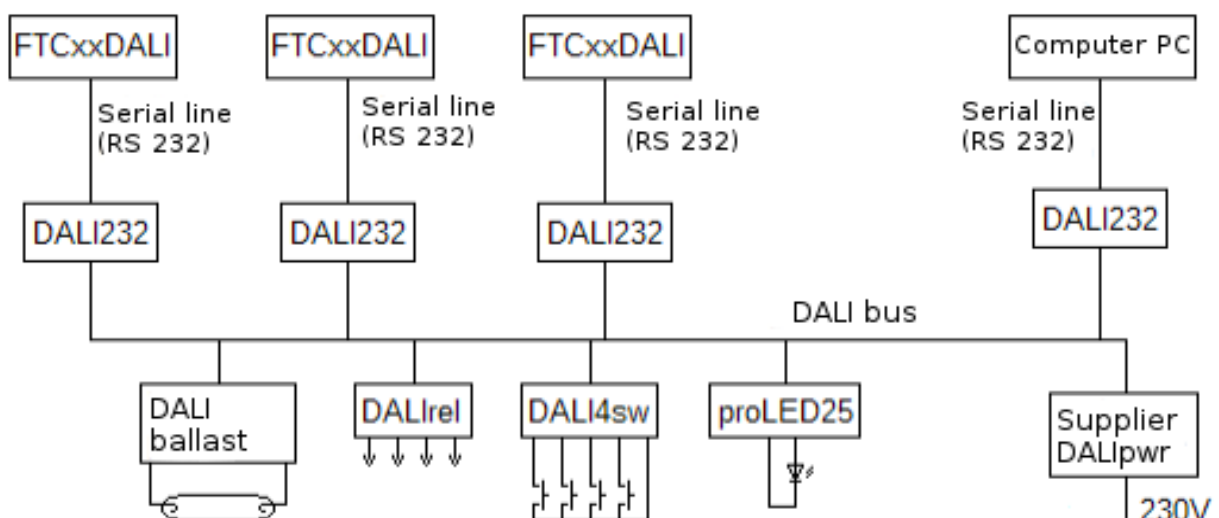

Dimensions (in mm)

